

File or sand 4 corners to mate with machined flange.

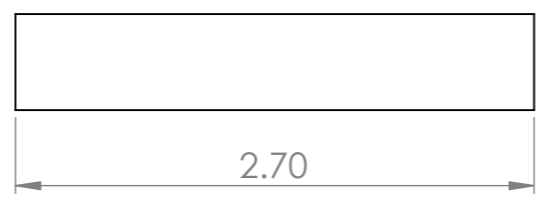
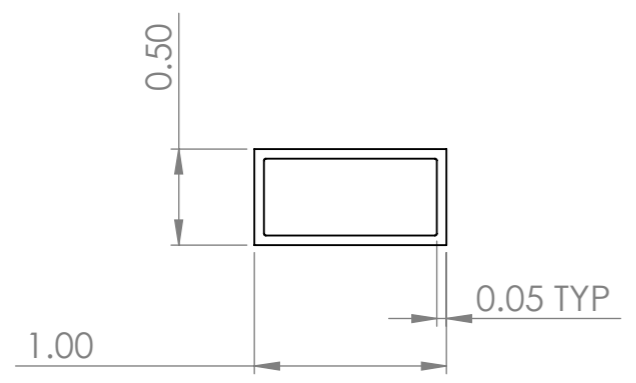

Face off Each end of tubing.  
Drill hole pattern and tap 2 holes.  
Standard stock rectangular Brass Tubing

UNLESS OTHERWISE SPECIFIED: DIMENSIONS ARE IN INCHES SURFACE FINISH: TOLERANCES: LINEAR: .005 ANGULAR:				FINISH:		DEBUR AND BREAK SHARP EDGES		DO NOT SCALE DRAWING		REVISION	
DRAWN				NAME		SIGNATURE		DATE		TITLE: N5BRG	
CHK'D											
APPV'D											
MFG											
Q.A								MATERIAL: Brass		DWG NO. WaveGuide	
								WEIGHT:		SCALE:1:1	
										SHEET 1 OF 1	
										A3	